

**APPLICATION**

The D2D series LED Dusk to Dawn Area Luminaire provides a cost efficient and long lasting solution for area lighting applications. With a standard 10 year warranty and class leading photometric performance, the D2D allows customers to enjoy the benefits of a quality made LED fixture with peace of mind. With more than 5 years in the LED market, the D2D Luminaire is a proven winner amongst many satisfied customers.

**SPECIFICATION FEATURES**

**A... Photocontrol**

Available 3 pin, 5 pin, or 7 pin receptacles. Long Life twenty (20) year rated twist lock photocontrols also available.

**B... Housing**

Housing is made of quality die cast aluminum. Standard grey polyester powder coat paint.

**C... Electronics**

High quality solid state electronic drivers and advanced surge protection paired with high performance LEDs create unmatched photometric performance and class leading protection for your LED product.

**D... Reflector**

Reflector consist of 1 mm thick hydroformed aluminum for increased rigidity and durability.

**E... Lens**

High performance acrylic lens. IES Type V.

**F... Mounting**

Fixture comes equipped with a clamping bracket and leveling steps to ensure proper, level installation. Bracket is secured with two (2) 3/8" x 1 1/2" stainless steel bolts and can fit 1 1/4" and up to 2" diameter arms. (1 1/4" x 21" utility grade arms can be purchased separately)

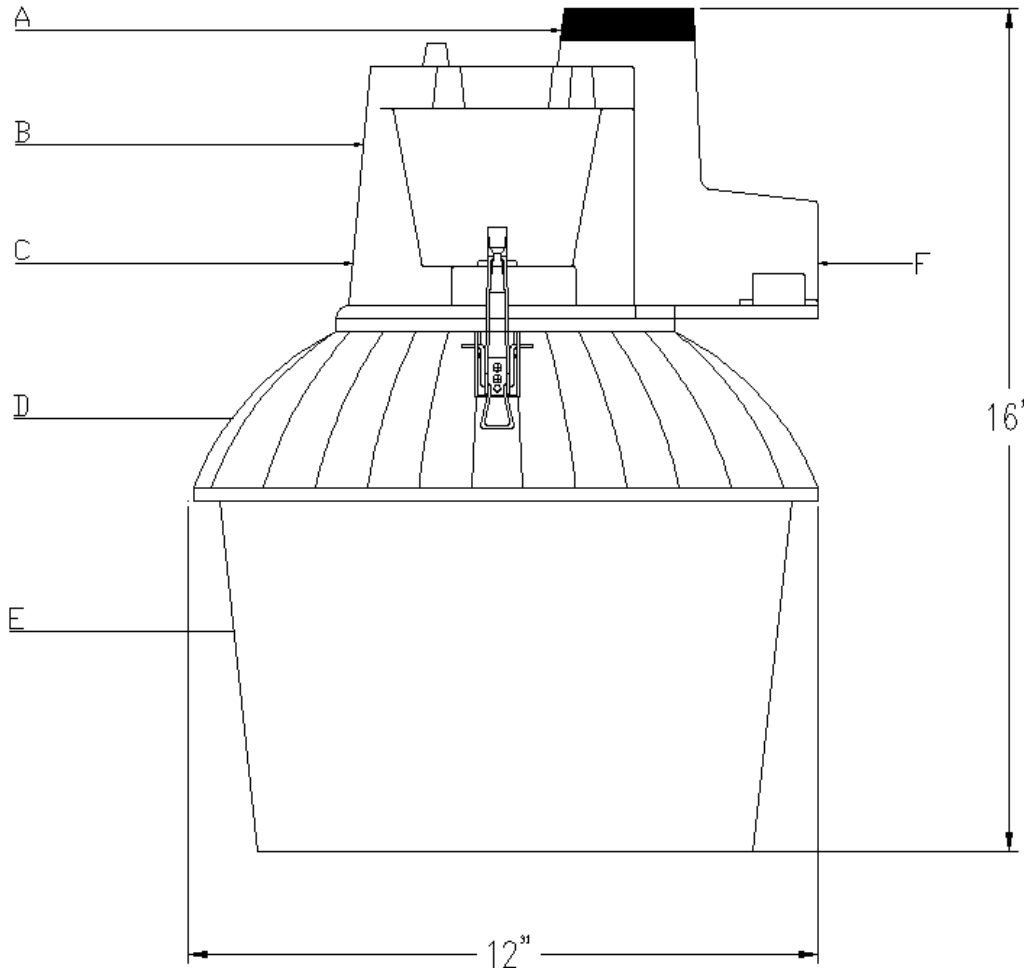

**D2D  
AREA  
LUMINAIRE**

**35W LED  
40W LED  
70W LED**

**EPA  
Effective Projected Area:  
1.2 Square Feet**

**Approximate Net Wt: 6 lbs**



35W LED, 4000K, TYPE V (4,001 LUMENS)

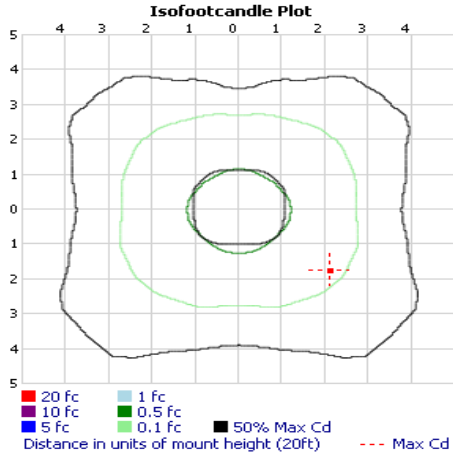

40W LED, 4000K, TYPE V (4,403 LUMENS)

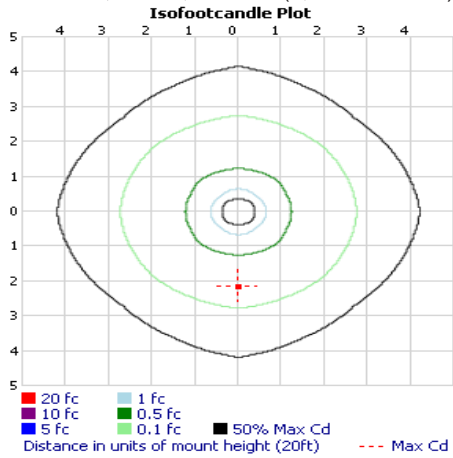

70W LED, 4000K, TYPE V (6,747 LUMENS)

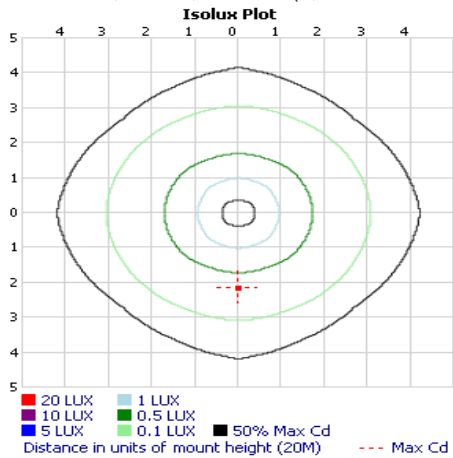

The D2D Fixture is 95% power factor corrected, thermal overload protected, electrical short/ overload protected, and has <20% total harmonic distortion. The D2D fixture has been through a number of test including In Situ Thermal, Energy Star TM-21, IESNA LM-79, IESNA LM-80 and 3G vibration tested. The D2D has a rated system life of over 100,000 hours and has a 90% lumen maintenance at 100,000 hours.

DLC APPROVED

The 40w D2D Luminaire is also DLC approved. The DLC approved version offers a full cutoff fixture (no refractor) so that there is no wasted uplight. It also comes standard with a 36kV/18kA surge protector included for extreme protection. Take advantage of many government approved rebate programs by purchasing DLC qualified products.



ORDERING INFORMATION

SAMPLE NUMBER: D2D40LE2554K23PLLPC

D2D PRODUCT FAMILY D2D	40 WATTAGE	L LAMP TYPE L = LED	E BALLAST TYPE E = ELEC. DRIVER D = DIMMABLE DRIVER	2 VOLTAGE 2 = 120-277V	55 DISTRIBUTION 33 = TYPE III 55 = TYPE V	4K CCT 3K = 3000K 4K = 4000K 5K = 5000K	2 SURGE PROTECTION 0 = NONE 1 = 20kV/10kA 2 = 36kV/18kA	3P LLPC OPTIONS COB = CHIP ON BOARD HIGH OUTPUT LED 3P = 3 PIN PHOTOCONTROL RECEPTACLE 7P = 7 PIN PHOTOCONTROL RECEPTACLE LLPC = LONG LIFE TWIST LOCK PHOTOCONTROL DS = DLC APPROVED (40W ONLY) SC = SHORTING CAP
	35 = 35W 40 = 40W 70 = 70W							

